

(SERVO, Not included in kit!)

Construction kit "ADF"

Your kit contains all the necessary components (except for a servomotor) for building an "ADF".

Fine-tuning

The calibration software allows you to accurately adjust the instrument (once connected to the Central Control Unit) to the movement of the needle of the chosen instrument.

Difficulty level

This product can be constructed without technical expertise. Knowledge of electronics soldering is required. Care and accuracy are of utmost importance.

What else do you need?

A modified servomotor, type HS300, HS311 or equivalent, is required to make the instrument fully functional (for modifying a servomotor, see the separate manual). This product can be ordered separately or bought from any retailer of model kits. Additionally you will need some simple tools, such as a small star-shaped screwdriver, a hobby knife, some pliers, a small hammer, a 1/16" (4 mm) drill, a 0.26" (6.5 mm) drill, a soldering iron (suitable for fine electronics), tin solder, insulating adhesive tape, superglue and glue suitable for plastic model kits.

General hints

Be very careful when using the hobby knife! You can easily hurt yourself when handling sharp objects! Take good care of the amount of glue you apply and to which areas you apply it. Glue for plastics is essentially a solvent. Excessive use can damage the exterior of the instrument.

Preparations before construction

Check if all components are included. During packing, the contents of the construction kit have been inspected several times. Nothing should be missing.

Use the hobby knife to remove any irregularities. Be careful when using the sharp hobby knife!

Remark

It is strongly recommended to assemble the ADF first without using any glue and use the calibration for testing. When everything works fine, you can use glue for final assembly.

Warranty

Construction kits come without a warranty!

List of components

A - Metal button
 AA- Inbus key
 B - Bolt (inbus)
 C - Strain relief
 D - Printed Circuit Board
 E - Compass ring
 F - Indicator lower plate
 G - Indicator lower ring
 H - Indicator lower disc
 I - Plate
 J - Shaft with arms
 K - Upper cap for adjusting compass ring
 L - Lower cap for adjusting compass ring
 M - Needle
 O - Hollow gearwheel 1
 P - Gearwheel with shaft, short
 Q - Hollow gearwheel 2
 R - Gearwheel with shaft, long
 S - Fastening cap 1
 T - Fastening cap 2
 U - Servo cap
 V - Tilted gearwheel
 W - Straight gearwheel
 X - Shaft for straight gearwheel
 Z - Shaft for adjusting compass card
 Z1 - Spring for adjusting compass card
 A1 - Front ring
 A2 - Front optical
 A3 - Upper casing
 A4 - Lower casing
 A5 - Light
 A6 - 2-wire cable
 A7 - Sleeve
 A9 - Self-tapping screw for mounting PCB

1

Modify an HS300 or HS311 servo, or order a modified servo through the SimKits webshop. See separate manual for modification process.

5

VIZ

2

0.26" (6.5 mm.)

Drill into the lower left hole (seen from the front) of front ring B, until it has a diameter of 0.26" / 6.5 mm.

6

Fix shaft X to component L. Make sure shaft X sticks out by exactly 0.16" (4 mm).

0.16" (4 mm.)

3

Place optical F into front ring A1 and cement it by sparingly applying glue to the back of the front ring, in the edge where optical and front ring connect.

7

Now connect gear wheel W to shaft X.

4

Carefully connect gearwheel V to shaft Z. Use component K as an aid. See also drawing 13.

8

Use a file to smoothen the sharp edges of spring Z1, to allow it to turn freely inside component L later.

Insert spring Z1 into component L.

9

Component O is made of nylon. This means that cementing of components O and U must be done with superglue!

13

10

14

Now place component K and shaft Z (with gearwheel V mounted) onto component L and press K and L together.

11

Component Q is made of nylon. This means that cementing of components Q and J must be done with superglue!

15

Glue components K and L together. Make sure when applying glue that shaft and gearwheels can continue to move freely. Keep pressing together components K and L for a duration of 5 minutes after applying the glue.

12

16

Remove the tags from indicator lower disc **H** as demonstrated in the drawing.

17

G/H/J/Q

21

Now place lower disc **H** onto shaft with arms **J**.

18

Turn around components **G/H/J/Q** and press them together tightly. While keeping them pressed, use the side of the soldering iron to flatten the pins and secure component **G** into place.

22

H and **J** combined.

19

Now press component **F** tightly down onto component **G/H/J/Q** until it can't be pressed down further.

23

Place indicator lower ring **G** onto the combined components **H** and **J**.

20

F/G/H/J/Q

24

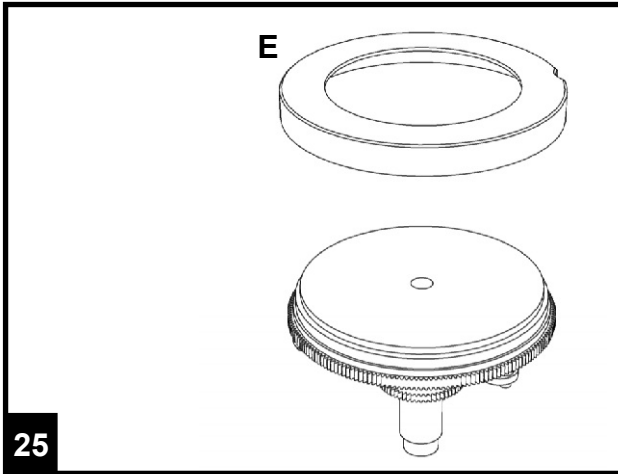

25

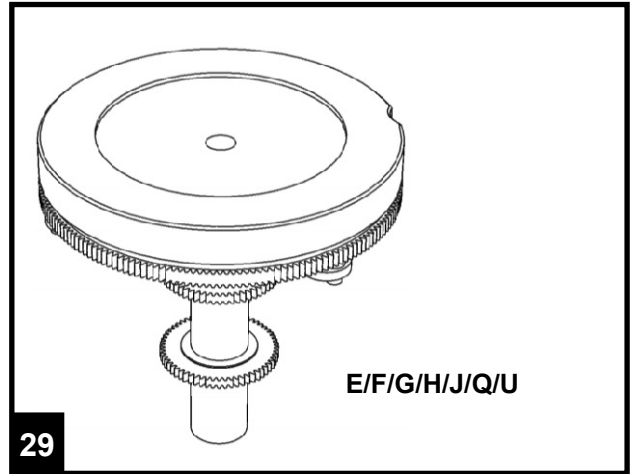

29

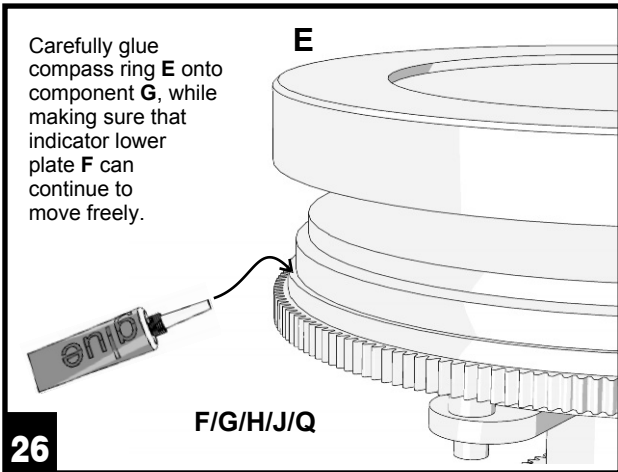

26

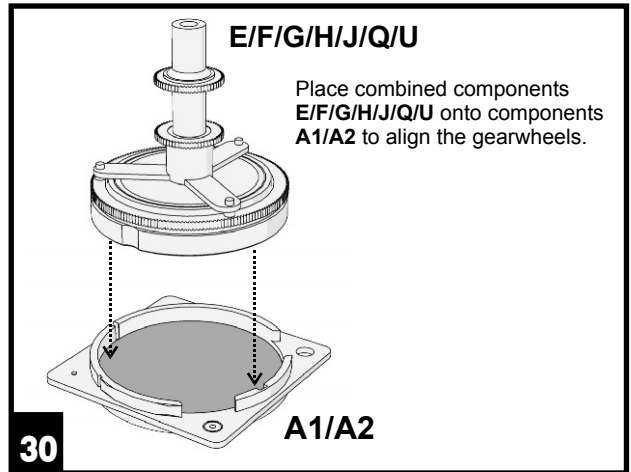

30

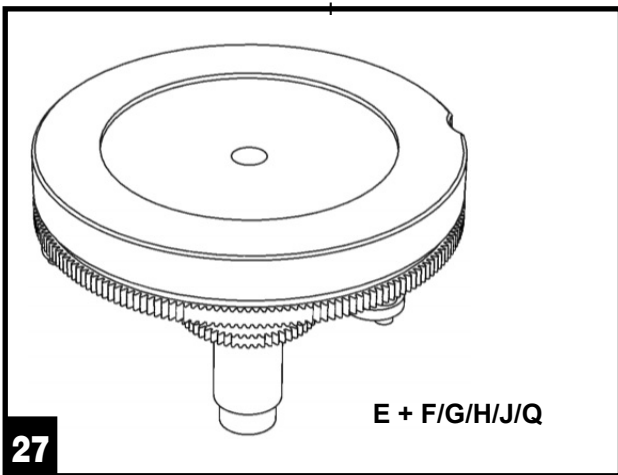

27

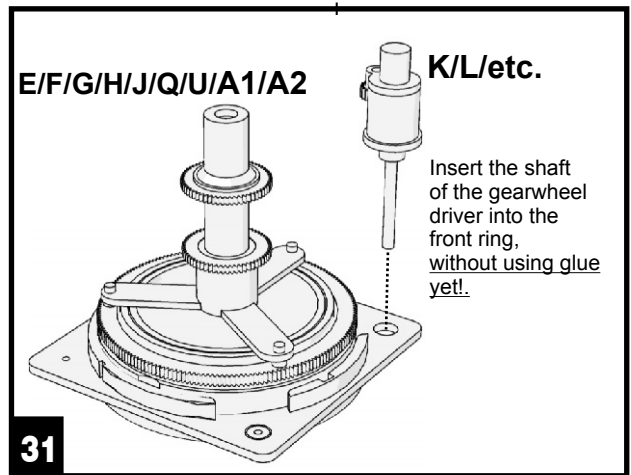

31

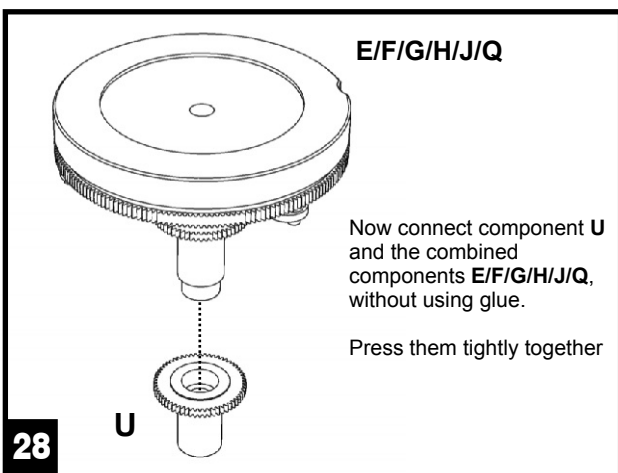

28

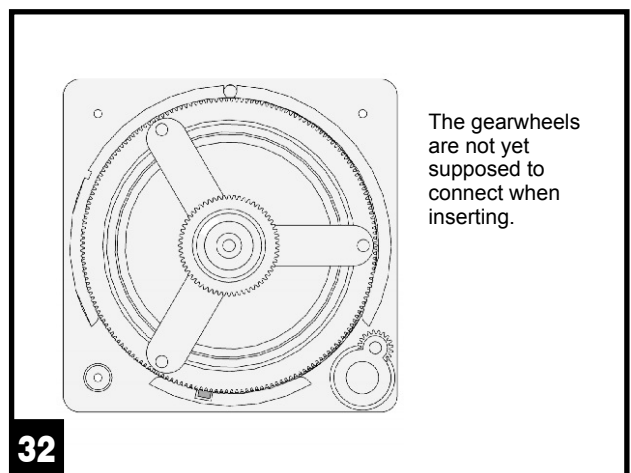

32

Carefully twist the small gearwheel component against the large gearwheel. Make sure to give the gearwheels just enough space to twist smoothly.

33

Connect the servo at point **S1** and mind the right position (see colour)

37

Cement the gearwheel casing to the front ring.

34

38

Connect cord **A6** to light **A5**. Use sleeve **A7** to insulate the soldered connection, but leave roughly 8 mm's worth of wire free at the base of the light. The sleeve shrinks when heated.

35

Check if the PIHER positioners, present on both sides of the circuit board, are in properly arrangement, as indicated in drawings **39** and **40**.

39

Connect the wires to the circuit board. Polarities are not important.

36

Mind the proper arrangement of the PIHER positioners!

40

41

Mount plate I onto circuit board D, using the positioning notches. Do not use screws just yet

45

!!!!
superglue

Using superglue, cement caps S and T onto the gearwheel shafts.
TAKE NOTE: Under no circumstances should the PIHER positioners come into contact with glue!

42

In this drawing the connections between servo and circuit board have been omitted for the sake of clarity. For the remainder of the assemblage it is assumed that these are connected to the circuit board as indicated in drawings 37 and 38.

46

A9

Screw the circuit board onto the plate using screw A9 (included).

43

Insert gearwheels R (longer shaft) and P (shorter shaft) into the caps on the plate.

47

Unfasten two diagonally placed long screws from the servo casing as indicated in the illustration.

Remove the disc from the servo shaft and save the screw.

Modified servo

44

Make sure the PIHER positioners are properly arranged as indicated in drawings 39 and 40. Once the shafts of gearwheels P and R are in position, you can carefully check whether they can twist freely.

48

A4

Place the modified servo into lower casing A4 and use the screws you previously unfastened from the servo to lock it into position.

Take note: do not wind the screws too tight! It's easy to overturn the thread inside the servo case!

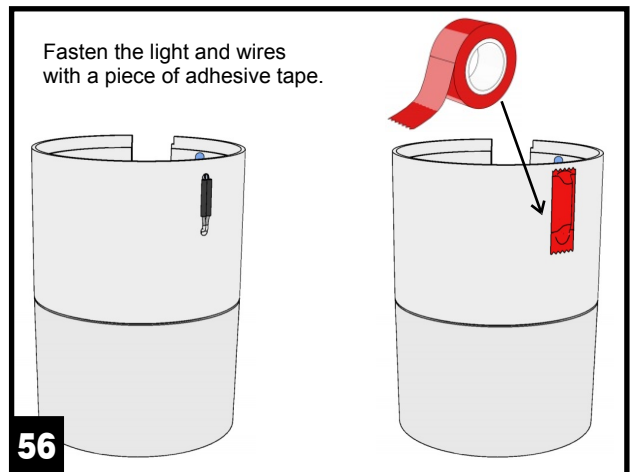
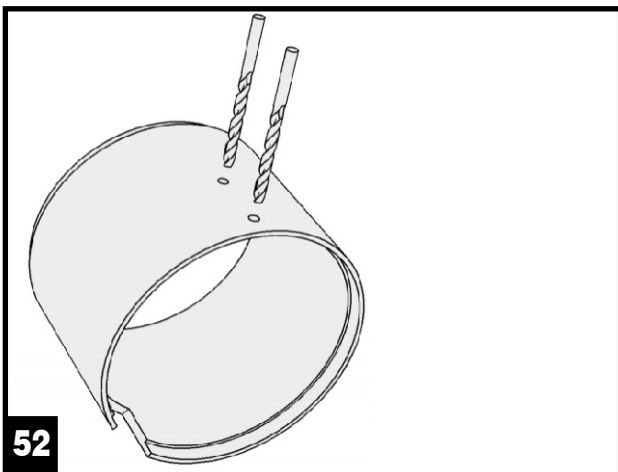
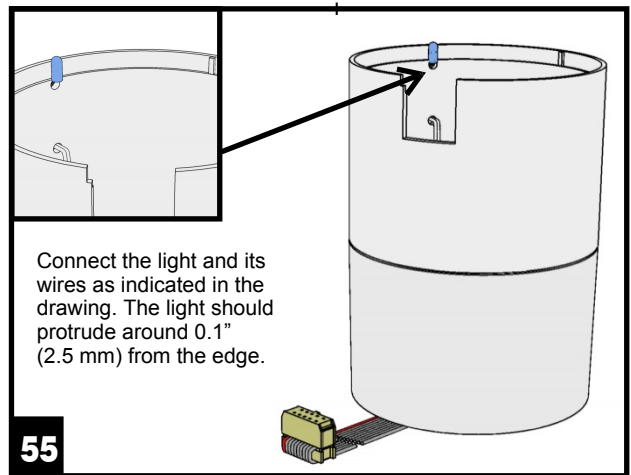
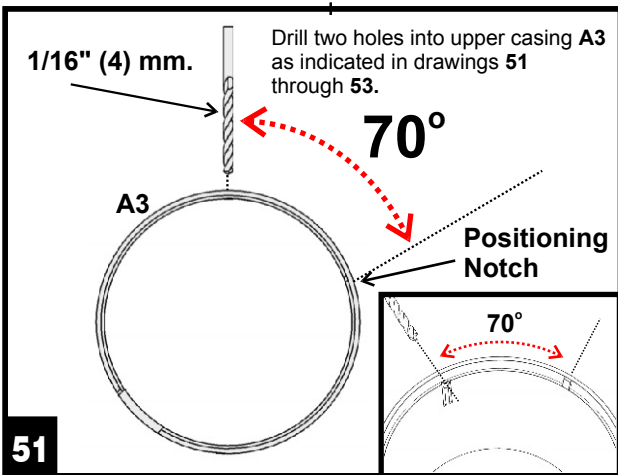
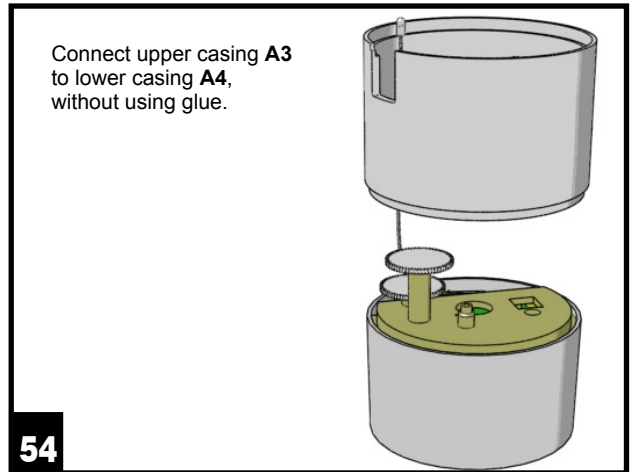
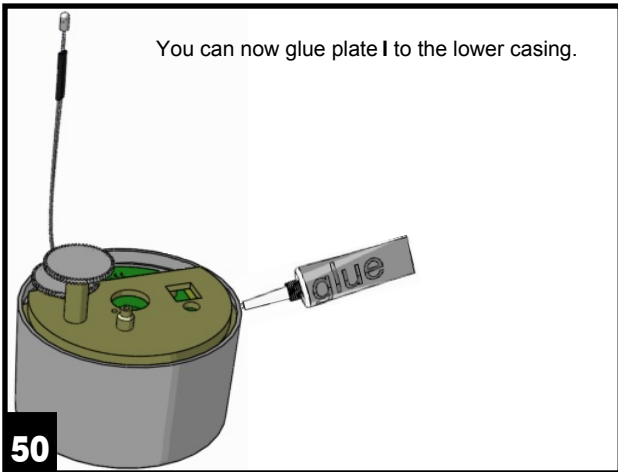
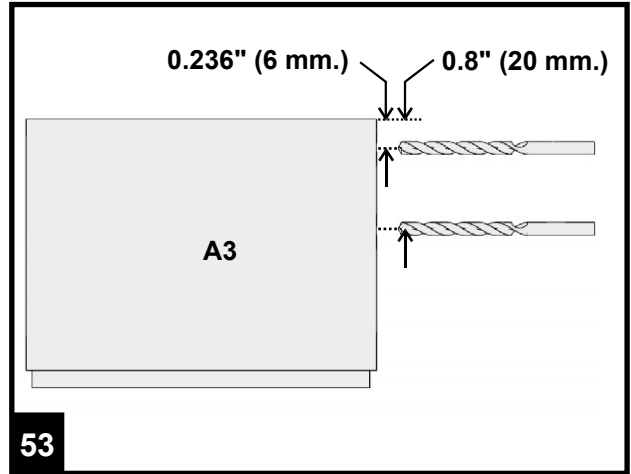
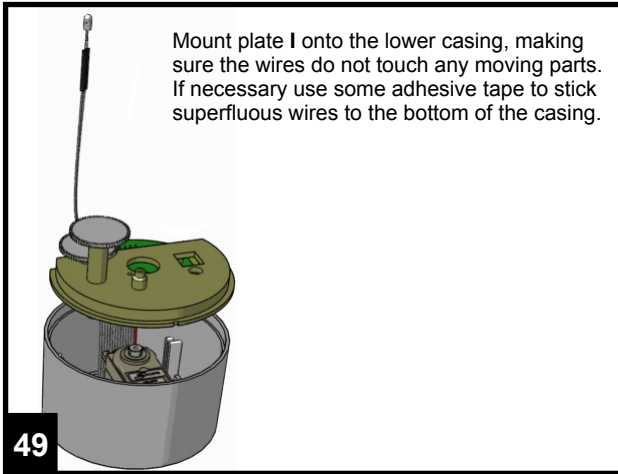

Insert the combined components **E/F/G/H/J/Q/U** into the casing and centre the shaft to the servo. Then mount the shaft to the servo using the servo's own screw.

57

Mount knob **A** to the shaft of the gearwheel mechanism, using bolt **B** and inbus key **AA**.

61

58

Connect the ADF to the Central Control Unit and check if it functions properly by using the calibration software.

62

Mount needle **M** to plate **F**.

59

The strain relief needs to be filed down somewhat to facilitate the 14-pin flat cable.

63

Mount the front ring with gearwheel driver to the upper casing. Take note: There is a small indentation in the compass ring, which will facilitate fitting the front ring with gearwheel driver. Carefully twist this indentation into the position shown in the illustration.

60

Once everything functions properly, you can cement the strain relief, lower casing and front ring.

64